

TECHNICAL SPECIFICATIONS

ARTIK 4



TECHNICAL DATA

ARTIK 4			21	23	25	27	29
CELLS	NUMBER		63	63	63	63	63
	CLOSED		10	10	10	10	10
	BOX		23	23	23	23	23
FLAT	AREA	M ²	21	23	24,5	26,5	29
	SPAN	M	11,32	11,85	12,23	12,71	13,3
	ASPECT RATIO		6,1	6,1	6,1	6,1	6,1
PROJECTED	AREA	M ²	17,8	19,5	20,77	22,46	24,59
	SPAN	M	9,01	9,43	9,73	10,12	10,59
	ASPECT RATIO		4,6	4,6	4,6	4,6	4,6
FLATTENING		%	15	15	15	15	15
CORD	MAXIMUM	M	2,28	2,4	2,47	2,56	2,68
	MINIMUM	M	0,53	0,55	0,57	0,59	0,62
	AVERAGE	M	1,85	1,94	2	2,08	2,18
LINES	TOTAL METERS	M	226	237	245	255	267
	HEIGHT	M	6,9	7,22	7,46	7,75	8,11
	NUMBER		227	227	227	227	227
	MAIN		2/3/2	1/1/2/3	1/1/2/3	2/3/2	2/3/2
	RISERS		3/4	A/B/C	A/A'/B/C	A/A'/B/C	A/B/C
ACCELERATOR	TRIMS		NO	NO	NO	NO	NO
	ACCELERATOR	M/M	105	150	150	150	150
	TOTAL WEIGHT	MINIMUM	KG	60	60	75	90
IN FLIGHT	MAXIMUM	KG	73	80	95	110	126
GLIDER WEIGHT		KG	4,5	4,9	5,2	5,5	5,8
CERTIFICATION	EN/LTF	C	C	C	C	C	C

MATERIALS TECHNICAL DATA

CANOPY	FABRIC CODE	SUPPLIER
UPPER SURFACE	9017 E25	PORCHER IND (FRANCE)
BOTTOM SURFACE	D20DMF-36	DOMINICO TEX CO (KOREA)
RIBS	9017 E29	PORCHER IND (FRANCE)
DIAGONALS	9017 E29	PORCHER IND (FRANCE)
LOOPS	LKI - 10	KOLON IND. (KOREA)
REINFORCEMENT LOOPS	W-420	D-P (GERMANY)
TRAILING EDGE REINFORCEMENT	MYLAR	D-P (GERMANY)
REINFORCEMENT RIBS	NYLON STICK	R.P.CHINA
THREAD	SERAFIL 60	AMAN (GERMANY)

SUSPENSION LINES	FABRIC CODE	SUPPLIER
UPPER CASCADES	DC - 40	LIROS GMHB (GERMANY)
UPPER CASCADES	DC - 60	LIROS GMHB (GERMANY)
UPPER CASCADES	DC - 100	LIROS GMHB (GERMANY)
UPPER CASCADES	12100-50	COUSIN (FRANCE)
MIDDLE CASCADES	DC - 40	LIROS GMHB (GERMANY)
MIDDLE CASCADES	DC - 60	LIROS GMHB (GERMANY)
MIDDLE CASCADES	DC - 100	LIROS GMHB (GERMANY)
MIDDLE CASCADES	12240-115	COUSIN (FRANCE)
MIDDLE CASCADES	12470-200	COUSIN (FRANCE)
MIDDLE CASCADES	16140-70	COUSIN (FRANCE)
MIDDLE CASCADES	16330-145	COUSIN (FRANCE)
MIDDLE CASCADES	12100-50	COUSIN (FRANCE)
MIDDLE CASCADES	12240-115	COUSIN (FRANCE)
MAIN	16560-240	COUSIN (FRANCE)
MAIN	12470-200	COUSIN (FRANCE)
MAIN	16140-70	COUSIN (FRANCE)
MAIN	12950-405	COUSIN (FRANCE)
MAIN BREAK	TNL-280	TEIJIM LIMITED (JAPAN)
THREAD	SERAFIL 60	AMAN (GERMANY)

RISERS	FABRIC CODE	SUPPLIER
MATERIAL	3455	COUSIN (FRANCE)
COLOR INDICATOR	PAD	TECNI SANGLES (FRANCE)
THREAD	V138	COATS (ENGLAND)
MAILLONS	AS-3.8-20	ANSUNG PRECISION (KOREA)
PULLEYS	224	HARKEN (USA)

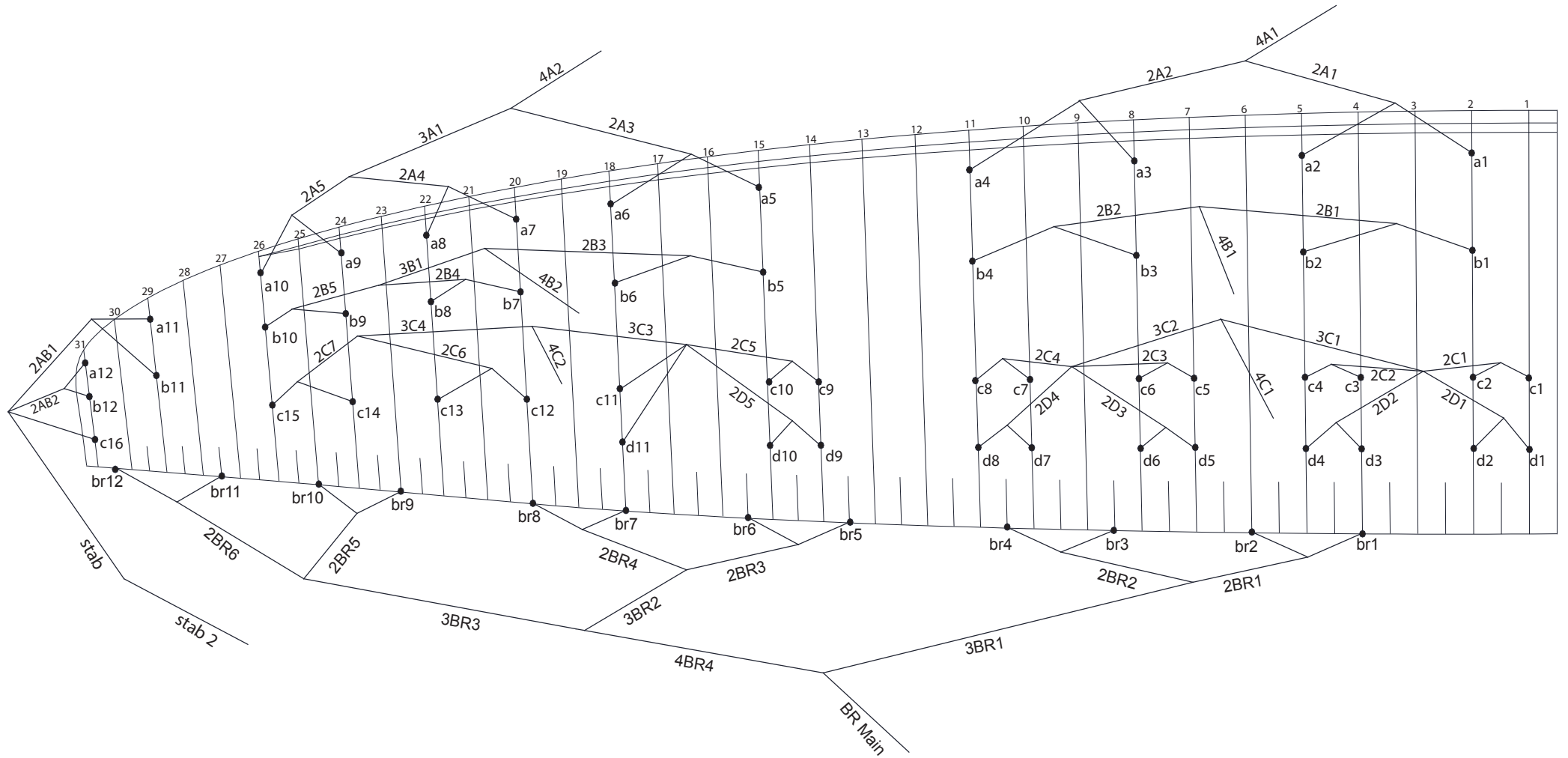

SIZE 23-25



SIZE 21-27-29



COLORS TECHNICAL DATA

SEA	1	ROYAL BLUE	MAIN TOP	REF: 317
	2	ROYAL BLUE	MAIN BOTTOM	REF: 317
	3	ORANGE	HORN	REF: 744
	4	BLACK	PRINCIPAL SHADOW	REF: 102
	5	WHITE	VOLUME SHADOW	REF: 001



SANDIA	1	DRAGON RED	MAIN TOP	REF: 636
	2	DRAGON RED	MAIN BOTTOM	REF: 636
	3	LIMA	HORN	REF: NK375
	4	BLACK	PRINCIPAL SHADOW	REF: 102
	5	WHITE	VOLUME SHADOW	REF: 001



ABAC	1	LIMA	MAIN TOP	REF: NK375
	2	LIMA	MAIN BOTTOM	REF: NK375
	3	WHITE	HORN	REF: 001
	4	BLACK	PRINCIPAL SHADOW	REF: 102
	5	ORANGE	VOLUME SHADOW	REF: 744



TEAK	1	RUBI	MAIN TOP	REF: NK259
	2	RUBI	MAIN BOTTOM	REF: NK259
	3	WHITE	HORN	REF: 001
	4	BLACK	PRINCIPAL SHADOW	REF: 102
	5	GOLD	VOLUME SHADOW	REF: 939

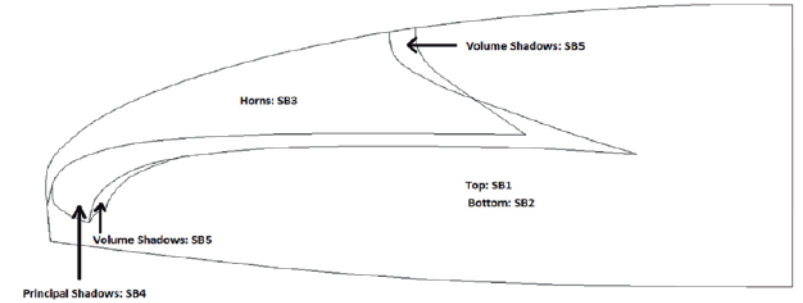

ARTIK 4

21		23		25		27		29	
P.T.V.	KG/M ²	P.T.V.	KG/M ²	P.T.V.	KG/M ²	P.T.V.	KG/M ²	P.T.V.	KG/M ²
50	= 2,38	60	= 2,61	75	= 3,00	90	= 3,37	105	= 3,62
51	= 2,43	61	= 2,65	76	= 3,04	91	= 3,41	107	= 3,69
52	= 2,48	62	= 2,70	77	= 3,08	92	= 3,44	110	= 3,79
53	= 2,52	63	= 2,74	78	= 3,12	93	= 3,48	112	= 3,86
54	= 2,57	64	= 2,78	79	= 3,16	94	= 3,52	114	= 3,93
55	= 2,62	65	= 2,83	80	= 3,20	95	= 3,56	115	= 3,97
56	= 2,67	66	= 2,87	81	= 3,24	96	= 3,59	116	= 4,00
57	= 2,71	67	= 2,91	82	= 3,28	97	= 3,63	117	= 4,03
58	= 2,76	68	= 2,96	83	= 3,32	98	= 3,67	118	= 4,07
59	= 2,81	69	= 3,00	84	= 3,36	99	= 3,70	119	= 4,10
60	= 2,86	70	= 3,04	85	= 3,40	100	= 3,74	120	= 4,14
61	= 2,90	71	= 3,09	86	= 3,44	101	= 3,78	121	= 4,17
62	2,95	72	= 3,13	87	= 3,48	102	= 3,81	122	= 4,21
63	3,00	73	= 3,17	88	= 3,52	103	= 3,85	123	= 4,24
64	3,05	74	= 3,22	89	= 3,56	104	= 3,89	124	= 4,28
65	3,10	75	= 3,26	90	= 3,60	105	= 3,93	125	= 4,31
66	3,14	76	= 3,30	91	= 3,64	106	= 3,96	126	= 4,34
67	3,19	77	= 3,35	92	= 3,68	107	= 4,00	127	= 4,38
68	3,24	78	= 3,39	93	= 3,72	108	= 4,04	128	= 4,41
69	3,29	79	= 3,43	94	= 3,76	109	= 4,07	129	= 4,45
70	3,33	80	= 3,48	95	= 3,80	110	= 4,26	130	= 4,48

LINES TECHNICAL DATA

ARTIK 4					21																			
REF.	MAT.	KG	COLOR	m/m	REF.	MAT.	KG	COLOR	m/m	REF.	MAT.	KG	COLOR	m/m	REF.	MAT.	KG	COLOR	m/m	REF.	MAT.	KG	COLOR	m/m
A					B					C					D					BRAKE				
a1	DC	60	WHT	1.450	b1	DC	60	WHT	1.427	c1	DC	40	WHT	360	d1	DC	40	WHT	338	br1	DC	40	WHT	680
a2	DC	60	WHT	1.314	b2	DC	60	WHT	1.292	c2	DC	40	WHT	262	d2	DC	40	WHT	247	br2	DC	40	WHT	405
a3	DC	60	WHT	1.370	b3	DC	60	WHT	1.348	c3	DC	40	WHT	355	d3	DC	40	WHT	335	br3	DC	40	WHT	619
a4	DC	60	WHT	1.366	b4	DC	60	WHT	1.348	c4	DC	40	WHT	334	d4	DC	40	WHT	313	br4	DC	40	WHT	619
a5	DC	60	WHT	1.279	b5	DC	60	WHT	1.255	c5	DC	40	WHT	348	d5	DC	40	WHT	324	br5	DC	40	WHT	612
a6	DC	60	WHT	1.128	b6	DC	60	WHT	1.115	c6	DC	40	WHT	334	d6	DC	40	WHT	313	br6	DC	40	WHT	482
a7	DC	40	WHT	770	b7	DC	40	WHT	718	c7	DC	40	WHT	303	d7	DC	40	WHT	286	br7	DC	40	WHT	494
a8	DC	40	WHT	702	b8	DC	40	WHT	658	c8	DC	40	WHT	349	d8	DC	40	WHT	323	br8	DC	40	WHT	535
a9	DC	40	WHT	669	b9	DC	40	WHT	655	c9	DC	40	WHT	331	d9	DC	40	WHT	347	br9	DC	40	WHT	470
a10	DC	40	WHT	683	b10	DC	40	WHT	689	c10	DC	40	WHT	259	d10	DC	40	WHT	275	br10	DC	40	WHT	440
a11	12100	50	ORG	936	b11	12100	50	ORG	901	c11	DC	60	WHT	1.003	d11	DC	40	WHT	1.077	br11	DC	40	WHT	527
a12	12100	50	ORG	647	b12	12100	50	ORG	639	c12	DC	40	WHT	570						br12	DC	40	WHT	633
										c13	DC	40	WHT	530										
										c14	DC	40	WHT	443										
										c15	DC	40	WHT	525										
										c16	12100	50	ORG	1.473										
2A1	12240	115	ORG	1.555	2B1	12240	115	ORG	1.531	2C1	DC	60	WHT	891	2D1	DC	40	WHT	1.004	2BR1	DC	40	WHT	986
2A2	12240	115	ORG	1.461	2B2	12240	115	ORG	1.441	2C2	DC	60	WHT	674	2D2	DC	40	WHT	796	2BR2	DC	40	WHT	561
2A3	12240	115	ORG	1.242	2B3	12240	115	ORG	1.214	2C3	DC	60	WHT	798	2D3	DC	40	WHT	918	2BR3	DC	40	WHT	815
2A4	16140	70	ORG	647	2B4	16140	70	ORG	670	2C4	DC	60	WHT	875	2D4	DC	40	WHT	979	2BR4	DC	40	WHT	734
2A5	16140	70	ORG	658	2B5	16140	70	ORG	655	2C5	DC	60	WHT	840	2D5	DC	40	WHT	895	2BR5	DC	40	WHT	499
2AB1	12100	50	ORG	628	3B1	12240	115	ORG	904	2C6	DC	60	WHT	522						2BR6	DC	40	WHT	432
2AB2	12100	50	ORG	787						2C7	DC	60	WHT	631										
3A1	12240	115	ORG	910						3C1	12240	115	ORG	1.030						3BR1	DC	60	WHT	3.180
										3C2	12240	115	ORG	851						3BR2	DC	60	WHT	1.264
										3C3	12240	115	ORG	979						3BR3	DC	60	WHT	1.514
										3C4	12240	115	ORG	877						4BR4	DC	100	WHT	1.566
4A1	16560	240	ORG	3.468	4B1	16560	240	ORG	3.426	4C1	12470	200	ORG	4.284						BR Main	TNL	280	red	2.462
4A2	16560	240	ORG	3.717	4B2	16560	240	ORG	3.692	4C2	12470	200	ORG	4.089						Point a :				2.262
										stab	16140	70	ORG	3.110										
										stab 2	TNL	80	RED	1.000										

LINES TECHNICAL DATA

ARTIK 4					23																			
REF.	MAT.	KG	COLOR	m/m	REF.	MAT.	KG	COLOR	m/m	REF.	MAT.	KG	COLOR	m/m	REF.	MAT.	KG	COLOR	m/m	REF.	MAT.	KG	COLOR	m/m
A					B					C					D					BRAKE				
a1	DC	60	WHT	1.518	b1	DC	60	WHT	1.493	c1	DC	40	WHT	377	d1	DC	40	WHT	354	br1	DC	40	WHT	711
a2	DC	60	WHT	1.377	b2	DC	60	WHT	1.354	c2	DC	40	WHT	274	d2	DC	40	WHT	259	br2	DC	40	WHT	424
a3	DC	60	WHT	1.433	b3	DC	60	WHT	1.410	c3	DC	40	WHT	371	d3	DC	40	WHT	351	br3	DC	40	WHT	648
a4	DC	60	WHT	1.430	b4	DC	60	WHT	1.411	c4	DC	40	WHT	350	d4	DC	40	WHT	329	br4	DC	40	WHT	648
a5	DC	60	WHT	1.339	b5	DC	60	WHT	1.314	c5	DC	40	WHT	364	d5	DC	40	WHT	340	br5	DC	40	WHT	640
a6	DC	60	WHT	1.181	b6	DC	60	WHT	1.167	c6	DC	40	WHT	350	d6	DC	40	WHT	328	br6	DC	40	WHT	505
a7	DC	40	WHT	805	b7	DC	40	WHT	751	c7	DC	40	WHT	316	d7	DC	40	WHT	299	br7	DC	40	WHT	517
a8	DC	40	WHT	735	b8	DC	40	WHT	689	c8	DC	40	WHT	365	d8	DC	40	WHT	338	br8	DC	40	WHT	560
a9	DC	40	WHT	701	b9	DC	40	WHT	686	c9	DC	40	WHT	347	d9	DC	40	WHT	363	br9	DC	40	WHT	492
a10	DC	40	WHT	715	b10	DC	40	WHT	721	c10	DC	40	WHT	271	d10	DC	40	WHT	289	br10	DC	40	WHT	461
a11	12100	50	ORG	979	b11	12100	50	ORG	942	c11	DC	60	WHT	1.050	d11	DC	40	WHT	1.124	br11	DC	40	WHT	551
a12	12100	50	ORG	676	b12	12100	50	ORG	668	c12	DC	40	WHT	597						br12	DC	40	WHT	663
										c13	DC	40	WHT	555										
										c14	DC	40	WHT	464										
										c15	DC	40	WHT	550										
										c16	12100	50	ORG	1.541										
2A1	12240	115	ORG	1.625	2B1	12240	115	org	1.600	2C1	DC	60	WHT	932	2D1	DC	40	WHT	1.047	2BR1	DC	40	WHT	1.031
2A2	12240	115	ORG	1.531	2B2	12240	115	org	1.510	2C2	DC	60	WHT	706	2D2	DC	40	WHT	836	2BR2	DC	40	WHT	588
2A3	12240	115	ORG	1.300	2B3	12240	115	ORG	1.270	2C3	DC	60	WHT	834	2D3	DC	40	WHT	961	2BR3	DC	40	WHT	853
2A4	16140	70	ORG	677	2B4	16140	70	ORG	701	2C4	DC	60	WHT	917	2D4	DC	40	WHT	1.032	2BR4	DC	40	WHT	769
2A5	16140	70	ORG	689	2B5	16140	70	ORG	685	2C5	DC	60	WHT	879	2D5	DC	40	WHT	943	2BR5	DC	40	WHT	521
2AB1	12100	50	ORG	658	3B1	12240	115	ORG	947	2C6	DC	60	WHT	547						2BR6	DC	40	WHT	453
2AB2	12100	50	ORG	824						2C7	DC	60	WHT	660										
3A1	12240	115	ORG	953																				
										3C1	12240	115	ORG	1.076						3BR1	DC	60	WHT	3.326
										3C2	12240	115	ORG	892						3BR2	DC	60	WHT	1.321
										3C3	12240	115	ORG	1.027						3BR3	DC	60	WHT	1.586
										3C4	12240	115	ORG	920						4BR4	DC	100	WHT	1.642
4A1	16560	240	ORG	3.654	4B1	16560	240	ORG	3.610	4C1	12470	200	ORG	4.502						BR Main	TNL	280	red	2.624
4A2	16560	240	ORG	3.919	4B2	16560	240	ORG	3.893	4C2	12470	200	ORG	4.301						Point a :				2.424
										stab	16140	70	ORG	3.331										
										stab 2	TNL	80	RED	1.000										

LINES TECHNICAL DATA

ARTIK 4					25																			
REF.	MAT.	KG	COLOR	m/m	REF.	MAT.	KG	COLOR	m/m	REF.	MAT.	KG	COLOR	m/m	REF.	MAT.	KG	COLOR	m/m	REF.	MAT.	KG	COLOR	m/m
A					B					C					D					BRAKE				
a1	DC	100	WHT	1.567	b1	DC	100	WHT	1.541	c1	DC	40	WHT	389	d1	DC	40	WHT	365	br1	DC	40	WHT	734
a2	DC	100	WHT	1.422	b2	DC	100	WHT	1.399	c2	DC	40	WHT	284	d2	DC	40	WHT	268	br2	DC	40	WHT	438
a3	DC	100	WHT	1.479	b3	DC	100	WHT	1.455	c3	DC	40	WHT	383	d3	DC	40	WHT	363	br3	DC	40	WHT	668
a4	DC	100	WHT	1.477	b4	DC	100	WHT	1.457	c4	DC	40	WHT	361	d4	DC	40	WHT	340	br4	DC	40	WHT	669
a5	DC	100	WHT	1.382	b5	DC	100	WHT	1.356	c5	DC	40	WHT	375	d5	DC	40	WHT	351	br5	DC	40	WHT	661
a6	DC	60	WHT	1.220	b6	DC	60	WHT	1.205	c6	DC	40	WHT	361	d6	DC	40	WHT	339	br6	DC	40	WHT	522
a7	DC	60	WHT	831	b7	DC	60	WHT	775	c7	DC	40	WHT	326	d7	DC	40	WHT	309	br7	DC	40	WHT	533
a8	DC	40	WHT	759	b8	DC	40	WHT	711	c8	DC	40	WHT	377	d8	DC	40	WHT	350	br8	DC	40	WHT	578
a9	DC	40	WHT	723	b9	DC	40	WHT	708	c9	DC	40	WHT	358	d9	DC	40	WHT	375	br9	DC	40	WHT	507
a10	DC	40	WHT	738	b10	DC	40	WHT	744	c10	DC	40	WHT	279	d10	DC	40	WHT	298	br10	DC	40	WHT	476
a11	12100	50	ORG	1.010	b11	12100	50	ORG	972	c11	DC	60	WHT	1.084	d11	DC	40	WHT	1.166	br11	DC	40	WHT	568
a12	12100	50	ORG	698	b12	12100	50	ORG	690	c12	DC	40	WHT	616						br12	DC	100	WHT	685
										c13	DC	40	WHT	573										
										c14	DC	40	WHT	479										
										c15	DC	40	WHT	567										
										c16	12100	50	ORG	1.590										
2A1	12470	200	ORG	1.675	2B1	12470	200	ORG	1.650	2C1	DC	60	WHT	962	2D1	DC	40	WHT	1.086	2BR1	DC	40	WHT	1.064
2A2	12470	200	ORG	1.582	2B2	12470	200	ORG	1.560	2C2	DC	60	WHT	729	2D2	DC	40	WHT	870	2BR2	DC	40	WHT	608
2A3	16330	145	ORG	1.341	2B3	16330	145	ORG	1.311	2C3	DC	60	WHT	861	2D3	DC	40	WHT	998	2BR3	DC	40	WHT	880
2A4	16140	70	ORG	699	2B4	16140	70	ORG	724	2C4	DC	60	WHT	947	2D4	DC	40	WHT	1.071	2BR4	DC	40	WHT	794
2A5	16140	70	ORG	712	2B5	16140	70	ORG	708	2C5	DC	60	WHT	907	2D5	DC	40	WHT	979	2BR5	DC	40	WHT	537
2AB1	12100	50	ORG	679	3B1	12240	115	ORG	978	2C6	DC	60	WHT	564						2BR6	DC	40	WHT	468
2AB2	12100	50	ORG	850						2C7	DC	60	WHT	681										
3A1	12240	115	ORG	985																				
										3C1	16330	145	ORG	1.110						3BR1	DC	60	WHT	3.432
										3C2	12240	115	ORG	922						3BR2	DC	60	WHT	1.363
										3C3	16330	145	ORG	1.062						3BR3	DC	60	WHT	1.638
										3C4	12240	115	ORG	952						4BR4	DC	100	WHT	1.697
4A1	12950	405	ORG	3.788	4B1	12950	405	ORG	3.742	4C1	16560	240	ORG	4.668						BR Main	TNL	280	red	2.719
4A2	16560	240	ORG	4.065	4B2	16560	240	ORG	4.038	4C2	16560	240	ORG	4.462						Point a :				2.519
										stab	16140	70	ORG	3.490										
										stab 2	TNL	80	RED	1.000										

LINES TECHNICAL DATA

ARTIK 4					27																			
REF.	MAT.	KG	COLOR	m/m	REF.	MAT.	KG	COLOR	m/m	REF.	MAT.	KG	COLOR	m/m	REF.	MAT.	KG	COLOR	m/m	REF.	MAT.	KG	COLOR	m/m
A					B					C					D					BRAKE				
a1	DC	100	WHT	1.629	b1	DC	100	WHT	1.603	c1	DC	40	WHT	405	d1	DC	40	WHT	380	br1	DC	40	WHT	763
a2	DC	100	WHT	1.480	b2	DC	100	WHT	1.456	c2	DC	40	WHT	295	d2	DC	40	WHT	279	br2	DC	40	WHT	456
a3	DC	100	WHT	1.537	b3	DC	100	WHT	1.512	c3	DC	40	WHT	399	d3	DC	40	WHT	378	br3	DC	40	WHT	694
a4	DC	100	WHT	1.536	b4	DC	100	WHT	1.516	c4	DC	40	WHT	376	d4	DC	40	WHT	354	br4	DC	40	WHT	696
a5	DC	100	WHT	1.437	b5	DC	100	WHT	1.410	c5	DC	40	WHT	390	d5	DC	40	WHT	365	br5	DC	40	WHT	687
a6	DC	60	WHT	1.269	b6	DC	60	WHT	1.254	c6	DC	40	WHT	376	d6	DC	40	WHT	353	br6	DC	40	WHT	543
a7	DC	60	WHT	864	b7	DC	60	WHT	806	c7	DC	40	WHT	339	d7	DC	40	WHT	321	br7	DC	40	WHT	554
a8	DC	40	WHT	790	b8	DC	40	WHT	740	c8	DC	40	WHT	392	d8	DC	40	WHT	364	br8	DC	40	WHT	601
a9	DC	40	WHT	752	b9	DC	40	WHT	736	c9	DC	40	WHT	372	d9	DC	40	WHT	390	br9	DC	40	WHT	528
a10	DC	40	WHT	768	b10	DC	40	WHT	774	c10	DC	40	WHT	291	d10	DC	40	WHT	310	br10	DC	40	WHT	495
a11	12100	50	ORG	1.051	b11	12100	50	ORG	1.011	c11	DC	60	WHT	1.128	d11	DC	40	WHT	1.214	br11	DC	40	WHT	591
a12	12100	50	ORG	725	b12	12100	50	ORG	717	c12	DC	40	WHT	641						br12	DC	100	WHT	713
										c13	DC	40	WHT	595										
										c14	DC	40	WHT	498										
										c15	DC	40	WHT	590										
										c16	12100	50	ORG	1.653										
2A1	12470	200	ORG	1.740	2B1	12470	200	ORG	1.714	2C1	DC	60	WHT	1.000	2D1	DC	40	WHT	1.131	2BR1	DC	40	WHT	1.106
2A2	12470	200	ORG	1.647	2B2	12470	200	ORG	1.624	2C2	DC	60	WHT	759	2D2	DC	40	WHT	901	2BR2	DC	40	WHT	633
2A3	16330	145	ORG	1.395	2B3	16330	145	ORG	1.363	2C3	DC	60	WHT	895	2D3	DC	40	WHT	1.033	2BR3	DC	40	WHT	914
2A4	16140	70	ORG	727	2B4	16140	70	ORG	753	2C4	DC	60	WHT	985	2D4	DC	40	WHT	1.106	2BR4	DC	40	WHT	827
2A5	16140	70	ORG	740	2B5	16140	70	ORG	736	2C5	DC	60	WHT	943	2D5	DC	40	WHT	1.009	2BR5	DC	40	WHT	558
2AB1	12100	50	ORG	706	3B1	12240	115	ORG	1.018	2C6	DC	60	WHT	587						2BR6	DC	40	WHT	487
2AB2	12100	50	ORG	884						2C7	DC	60	WHT	708										
3A1	12240	115	ORG	1.025																				
										3C1	16330	145	ORG	1.153						3BR1	DC	60	WHT	3.568
										3C2	12240	115	ORG	960						3BR2	DC	60	WHT	1.417
										3C3	16330	145	ORG	1.107						3BR3	DC	60	WHT	1.705
										3C4	12240	115	ORG	991						4BR4	DC	100	WHT	1.768
4A1	12950	405	ORG	3.960	4B1	12950	405	ORG	3.913	4C1	16560	240	ORG	4.875						BR Main	TNL	280	red	2.851
4A2	16560	240	ORG	4.252	4B2	16560	240	ORG	4.224	4C2	16560	240	ORG	4.663						Point a :				2.651
										stab	16140	70	ORG	3.695										
										stab 2	TNL	80	RED	1.000										

LINES TECHNICAL DATA

ARTIK 4					29																			
REF.	MAT.	KG	COLOR	m/m	REF.	MAT.	KG	COLOR	m/m	REF.	MAT.	KG	COLOR	m/m	REF.	MAT.	KG	COLOR	m/m	REF.	MAT.	KG	COLOR	m/m
A					B					C					D					BRAKE				
a1	DC	100	WHT	1.704	b1	DC	100	WHT	1.677	c1	DC	40	WHT	424	d1	DC	40	WHT	398	br1	DC	40	WHT	799
a2	DC	100	WHT	1.550	b2	DC	100	WHT	1.525	c2	DC	40	WHT	309	d2	DC	40	WHT	293	br2	DC	40	WHT	478
a3	DC	100	WHT	1.607	b3	DC	100	WHT	1.581	c3	DC	40	WHT	417	d3	DC	40	WHT	395	br3	DC	40	WHT	726
a4	DC	100	WHT	1.608	b4	DC	100	WHT	1.587	c4	DC	40	WHT	393	d4	DC	40	WHT	371	br4	DC	40	WHT	729
a5	DC	100	WHT	1.503	b5	DC	100	WHT	1.475	c5	DC	40	WHT	408	d5	DC	40	WHT	382	br5	DC	40	WHT	719
a6	DC	60	WHT	1.328	b6	DC	60	WHT	1.312	c6	DC	40	WHT	394	d6	DC	40	WHT	370	br6	DC	40	WHT	568
a7	DC	60	WHT	904	b7	DC	60	WHT	843	c7	DC	40	WHT	355	d7	DC	40	WHT	336	br7	DC	40	WHT	579
a8	DC	40	WHT	826	b8	DC	40	WHT	774	c8	DC	40	WHT	410	d8	DC	40	WHT	381	br8	DC	40	WHT	629
a9	DC	40	WHT	786	b9	DC	40	WHT	770	c9	DC	40	WHT	390	d9	DC	40	WHT	409	br9	DC	40	WHT	552
a10	DC	40	WHT	803	b10	DC	40	WHT	810	c10	DC	40	WHT	304	d10	DC	40	WHT	325	br10	DC	40	WHT	519
a11	12100	50	ORG	1.099	b11	12100	50	ORG	1.057	c11	DC	60	WHT	1.181	d11	DC	40	WHT	1.271	br11	DC	40	WHT	617
a12	12100	50	ORG	759	b12	12100	50	ORG	750	c12	DC	40	WHT	670						br12	DC	100	WHT	747
										c13	DC	40	WHT	623										
										c14	DC	40	WHT	521										
										c15	DC	40	WHT	617										
										c16	12100	50	ORG	1.729										
2A1	12470	200	ORG	1.819	2B1	12470	200	ORG	1.791	2C1	DC	60	WHT	1.046	2D1	DC	40	WHT	1.179	2BR1	DC	40	WHT	1.156
2A2	12470	200	ORG	1.725	2B2	12470	200	ORG	1.701	2C2	DC	60	WHT	796	2D2	DC	40	WHT	941	2BR2	DC	40	WHT	663
2A3	16330	145	ORG	1.459	2B3	16330	145	ORG	1.426	2C3	DC	60	WHT	935	2D3	DC	40	WHT	1.077	2BR3	DC	40	WHT	956
2A4	16140	70	ORG	760	2B4	16140	70	ORG	787	2C4	DC	60	WHT	1.031	2D4	DC	40	WHT	1.159	2BR4	DC	40	WHT	866
2A5	16140	70	ORG	775	2B5	16140	70	ORG	770	2C5	DC	60	WHT	987	2D5	DC	40	WHT	1.057	2BR5	DC	40	WHT	584
2AB1	12100	50	ORG	739	3B1	12240	115	ORG	1.067	2C6	DC	60	WHT	615						2BR6	DC	40	WHT	510
2AB2	12100	50	ORG	925						2C7	DC	60	WHT	740										
3A1	12240	115	ORG	1.073																				
										3C1	16330	145	ORG	1.204						3BR1	DC	60	WHT	3.732
										3C2	12240	115	ORG	1.006						3BR2	DC	60	WHT	1.481
										3C3	16330	145	ORG	1.161						3BR3	DC	60	WHT	1.785
										3C4	12240	115	ORG	1.039						4BR4	DC	100	WHT	1.852
4A1	12950	405	ORG	4.172	4B1	12950	405	ORG	4.117	4C1	16560	240	ORG	5.112						BR Main	TNL	280	red	2.958
4A2	16560	240	ORG	4.477	4B2	16560	240	ORG	4.448	4C2	16560	240	ORG	4.905						Point a :				2.758
										stab	16140	70	ORG	3.940										
										stab 2	TNL	80	RED	1.000										

NIVIUK ARTIK 4 21

LINES HEIGHT m/m

	A	B	C	D	br
1	6463	6374	6545	6630	7132
2	6327	6240	6446	6539	6857
3	6290	6205	6322	6425	6647
4	6285	6205	6306	6403	6647
5	6229	6151	6265	6361	6544
6	6078	6010	6251	6350	6414
7	6034	5974	6297	6389	6345
8	5967	5915	6343	6426	6385
9	5945	5896	6224	6300	6335
10	5959	5930	6151	6229	6306
11	5657	5622	6056	6135	6325
12	5526	5518	6044		6401
13			6004		
14			6025		
15			6107		
16			5570		

RISERS LENGHT m/m

	A	B	C	
	470	470	470	STANDARD
	344	374	470	ACCELERATED
	126	96	0	TRAVEL

NIVIUK ARTIK 4 23

LINES HEIGHT m/m

	A	B	C	D	br
1	6786	6693	6882	6973	7482
2	6645	6554	6780	6879	7195
3	6608	6520	6650	6760	6976
4	6605	6521	6629	6737	6977
5	6548	6466	6587	6690	6870
6	6390	6320	6573	6678	6735
7	6345	6282	6622	6720	6663
8	6275	6220	6670	6759	6706
9	6252	6201	6548	6639	6655
10	6267	6236	6472	6565	6624
11	5950	5913	6373	6456	6645
12	5813	5805	6360		6757
13			6318		
14			6340		
15			6425		
16			5858		

RISERS LENGHT m/m

	A	A'	B	C	
	470	470	470	470	STANDARD
	312	332	352	470	ACCELERATED
	158	138	118	0	TRAVEL

NIVIUK ARTIK 4 25

LINES HEIGHT m/m

	A	B	C	D	br
1	7020	6923	7119	7219	7739
2	6875	6781	7013	7122	7443
3	6838	6747	6880	7000	7217
4	6836	6749	6858	6977	7218
5	6778	6694	6816	6928	7110
6	6616	6543	6802	6916	6970
7	6570	6505	6853	6960	6896
8	6497	6441	6903	7001	6941
9	6474	6421	6779	6868	6889
10	6489	6458	6700	6791	6857
11	6161	6123	6599	6680	6880
12	6020	6012	6584		6981
13			6541		
14			6563		
15			6652		
16			6067		

RISERS LENGHT m/m

	A	A'	B	C	
	470	470	470	470	STANDARD
	312	332	357	470	ACCELERATED
	158	138	113	0	TRAVEL

NIVIUK ARTIK 4 27

LINES HEIGHT m/m

	A	B	C	D	br
1	7330	7230	7433	7539	8089
2	7181	7083	7323	7438	7781
3	7144	7049	7186	7312	7547
4	7143	7053	7163	7288	7549
5	7084	7002	7120	7234	7437
6	6916	6846	7106	7221	7293
7	6868	6801	7160	7267	7216
8	6793	6735	7212	7310	7263
9	6769	6715	7086	7180	7210
10	6786	6753	7004	7100	7178
11	6444	6404	6898	6984	7201
12	6296	6288	6883		7324
13			6838		
14			6861		
15			6953		
16			6340		

RISERS LENGHT m/m

	A	B	C	
	470	470	470	STANDARD
	312	352	470	ACCELERATED
	158	118	0	TRAVEL

LINES HEIGHT m/m

	A	B	C	D	br
1	7695	7590	7791	7903	8444
2	7541	7438	7677	7797	8123
3	7504	7399	7533	7661	7879
4	7505	7405	7510	7637	7881
5	7444	7353	7466	7586	7766
6	7269	7188	7452	7573	7620
7	7219	7147	7509	7622	7541
8	7141	7078	7564	7667	7591
9	7116	7057	7446	7535	7536
10	7133	7098	7361	7451	7502
11	6770	6733	7251	7338	7528
12	6615	6612	7229		7627
13			7182		
14			7206		
15			7293		
16			6666		

RISERS LENGHT m/m

	A	B	C	
	470	470	470	STANDARD
	312	352	470	ACCELERATED
	158	118	0	TRAVEL

SUSPENSION TECHNICAL DATA

ARTIK 4

MATERIAL CODE		DC	DC	DC	TNL	12100	12240	12470	12950	16140	16330	16560
STRENGTH CODE		40	060	100	280	50	115	200	405	70	145	240
DIAMETER m/m	Ø	0,5	0,6	0,8	1,8		0,9	1,2	1,6		1	1,4
CORE MATERIAL		DYNEEMA	DYNEEMA	DYNEEMA	TECHNORA	VECTRAM	VECTRAM	VECTRAM	VECTRAM	VECTRAM	VECTRAM	VECTRAM
SLEEVE MATERIAL		NO	NO	NO	POLYESTER	NO	NO	NO	NO	NO	NO	NO
WEIGHT G/M	TOTAL	0,19	0,24	0,42	2,7	0,28	0,9	1,17	2	0,39	0,77	1,59
BREAKING STRENGTH	MINIMUM	40	60	100	280	50	115	200	405	70	145	240
	MAXIMUM	48	84	110	320	53	122	215	430	74	153	255
STRENGTH AFTER												
5.000 BENDING	TEST EN	33	74	99	134,7	36	60,9	112,1	237,5	31	77,5	185,5
CYCLES												
ELONGATION AT	5 DAN EN %				0,2	0,4	0,2	0,2	0,35	0,75	0,2	0,1
	10 DAN EN %		0,43	0,36	0,3	0,9	0,4	0,3	0,4	1	0,4	0,3
	15 DAN EN %				0,4	1,3	0,4	0,4	0,5	1,1	0,7	0,4
	20 DAN EN %				0,4	1,5	0,9	0,5	0,7	1,4	0,8	0,5
	25 DAN EN %				0,5	1,9	1	0,6	0,9	1,75	0,9	0,6
	30 DAN EN %		1,2	1	0,9		1,6	1	1	2,75	1,5	1
	75 DAN EN %				1,3		2	1,4	1,3		2	1,2
	100 DAN EN %				1,7		3	1,7	1,7		2,4	1,5
	125 DAN EN %				2			2,1	1,8		3	1,9
	150 DAN EN %				2,3			2,4	1,9		3,6	2,1
	175 DAN EN %				2,7			2,8	2			2,4
	200 DAN EN %				2,8			3,2	2,4			2,7
	250 DAN EN %								2,7			3,1
ELONGATION MAX. BREAKING STRENGTH %			3,2	3,4	4,1	3,8	3,5	3,4	4,2	3,7	3,7	3,5

MAILLON TECHNICAL DATA

DESCRIPTION

MAILLON	DELTA
CODE	AS-3.8-20
MATERIAL	STAINLESS STEEL
SIZE	3,8 m/m
WEIGHT	10 G/PIECE

TECHNICAL SPECIFICATIONS

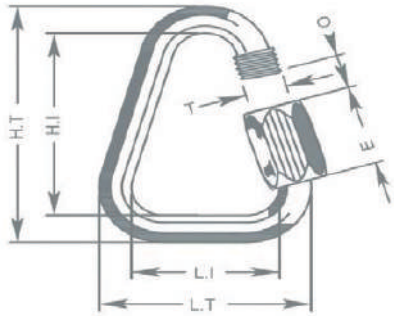

DIMENSIONS	m/m
L.T.	22
L.I.	14
H.T.	37
H.I.	29
O	4
E	11
T	4
LOAD	KG
WORKING LIMIT	150
BREAKING	750

MATERIAL

AISI 304 STAINLESS STEEL STANDARD

CLOSING APPLIED BY MANUAL & ENTIRE SCREWING OF THE NUT
TO GUARANTEE THE HIGHEST SAFETY (NO THREAD SHOULD BE OBVIOUS)

SYSTEMATIC CONTROL OF MAILLON QUICK-LINKS BEFORE EVERY FLIGHT

PULLEY TECHNICAL DATA

DESCRIPTION

PULLEY	20 m/m
CODE	RF25109
MATERIAL	STAINLESS STEEL
	NYLON
	CARBON ACETAL
BEARING	DELRIN®
WEIGHT	9 G/PIECE

TECHNICAL SPECIFICATIONS

DIMENSIONS	m/m
L.T.	20
L.I.	20
H.T.	32
Ø	6 MAX
LOAD	KG
WORKING LIMIT	250
BREAKING	550

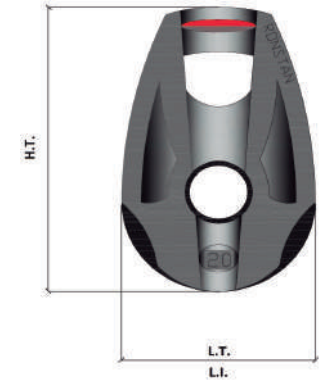

THREAD TECHNICAL DATA**SAIL MAKING**

NAME	SERAFIL
N° OF REFERENCE	60
MATERIAL	POLYESTER
TYPE OF FINISH	SILK
LINEAR DENSITY	NM 61 / 3 (DTEX 163 * 3)
BREAKING STRENGTH	3,000 CN
ELONGATION	17,00%

SERAFIL PROPERTIES

SOLIDITY ARTIFICIAL LIGTH	ISO 105 B02 > 5 - 6
SOLIDITY SWEAT	ISO 105 E04 > 4
SOLIDITY WASHING	ISO 105 C04 > 3
SOLIDITY GRAZE IN DRY	ISO 105 X12 > 4
SOLIDITY WASHING IN DRY	ISO 105 D01 > 3 - 4

TREATMENT WATER REPELLENT	WR
---------------------------	----

RISERS MAKING

NAME	COATS BONDED C.F.P.
N° OF REFERENCE	V138
MATERIAL	POLYESTER
TYPE OF FINISH	SILK
BREAKING STRENGTH	9,5 KG
ELONGATION	19%

RISERS TECHNICAL DATA**RISERS**

N° OF REFERENCE	3455
MATERIAL	POLYESTER & TECHNORA
WIDTH	12 M/M
THICKNESS	0,9 M/M
BREAKING STRENGTH	1.078 DAN
ELONGATION	MAX. 11%
WEIGHT	9,1 G * L.M.
COLOR	BLACK

COLOR INDICATOR

N° OF REFERENCE	IC-G 1-2
MATERIAL	POLYESTER
WIDTH	70 M/M
THICKNESS	0,80 M/M
BREAKING STRENGTH	130 DN
ELONGATION	35 %
WEIGHT	32 G * L.M.
COLOR	GREEN

LOOPS

N° OF REFERENCE	LKI - 10
MATERIAL	NYLON
WIDTH	10 M/M
BREAKING STRENGTH	84 KG
ELONGATION	30 %
WEIGHT	5,5 G/M
COLOR	WHITE

